



Designed for easy installation and trouble-free service, these high quality radial ball bearing-equipped rollers encompass Truth Hardware's unique advantage in that we manufacture our own ball bearings. This allows Truth complete control over all aspects of design and production of our roller assemblies. While others may use soft stamped metal parts in the production of their wheels, Truth's bearing raceways are machined from solid steel bar stock on the most modern automatic machines. These rollers are then heat treated for wear resistance and plated for corrosion resistance. This method provides the longest lasting true running rollers capable of carrying the heaviest loads.

- You can dependably support up to a 500 lb. door with two roller assemblies per door (nylon wheels rated up to a 250 lb. door). See Product Comparison Chart
- Truth's Side Adjust Tandem Rollers are equipped with full race, permanently lubricated ball bearings that are labyrinth-shielded to resist contamination by dust and moisture.
- The wheels are offered in various diameters and with a choice of steel, stainless steel, or nylon rolling surfaces.
- Truth's standard groove radius is .125 (+/- .010/.000).

Please refer to individual charts for dimensional details and adjustment ranges.

INDUSTRY TESTED

Steel roller components are zinc plated to ASTM-B-633 Type 2 specifications. All roller assemblies are designed to meet AAMA 906.3-96 and CAWM standards for corrosion resistance, load and life cycle specs. See Product Comparison Chart.

WARRANTY: Protected under the terms of the Truth Warranty for Window & Door Manufacturers & Authorized Distributors. For a copy of this warranty, please contact Truth.

MATERIAL: Heavy duty case carrier and support brackets are cold-rolled steel or stainless steel. Ball bearing wheels in steel, stainless steel or steel with nylon tires. High-pressure die-



cast zinc gear mechanism.

FINISH: All steel parts are zinc plated for corrosion resistance.

MOUNTING: Recess mounted into a variety of different door styles. Contact Truth for special information if your application does not provide side and top support for the roller assembly.

ORDERING INFORMATION AND OPTIONS:

1. Choose style of rollers desired. See tables in attached drawings for special information on adjustment features, mounting tab designs, and wheel materials offered.
2. If your application requires a modification to one of our standard rollers, or a complete new design, our staff and facilities are equipped to promptly handle your needs. Please contact Truth Hardware for assistance.

- To establish the initial specification for a roller application we need the following information:
- Wheel diameter: 1", 1-1/8", 1-1/4", 1-1/2".
- Housing: Steel, or stainless steel.
- Radius of the track crown.
- Internal width and internal height of the bottom rail.
- Maximum load to which rollers will be subjected.

Note: Truth can provide various wheel types (steel, stainless steel, nylon) to suit your application and/or environmental conditions. Please contact us

so we can help you select the style that will meet your needs.

RECOMMENDED SCREWS:

Types of screws required determined by material of profile used. Refer to drawings for complete information on screw type and quantity needed (sold separately).

TRUTH TIPS:

1. When a sliding Patio Door system has an aluminum track, a patio door roller with a nylon wheel must be used. If a steel wheel is used, gauling will occur, resulting in short track life.
2. It is important to match mounting screw material to the material being fastened. Consult Truth Tech Notes for more information.
3. Truth does not recommend adjusting the patio door rollers with power screwdrivers as it is possible to apply too much torque and damage the adjustment mechanism.

INCLUDE TRUTH SPECS ON YOUR NEXT PATIO DOOR PROJECT

Ball bearing roller assemblies must be provided which allow easy height adjustment and installation. Two steel wheeled roller assemblies with heat-treated raceways to support up to a 500 lb. door (250 lb. with nylon wheels). Sliding door rollers shall be Side Adjust Tandem Door Rollers as manufactured by Truth Hardware.

SIDE ADJUST TANDEM ROLLERS

Product Comparison Chart

Roller Assembly No.	Roller Dia.	AAMA Certified**	Max. Door Wt. *	Ease Of Adjustment	See Figure Number
39.10	1.25 (31.8 mm)	Yes	400 (182 Kg.)	Best	1
39.11	1.25 (31.8 mm)	Yes	250 (114 Kg.)	Best	1
39.13	1.25 (31.8 mm)	Yes	400 (182 Kg.)	Best	1
39.14	1.25 (31.8 mm)	Yes	400 (182 Kg.)	Best	1
39.20	1.25 (31.8 mm)	Yes	400 (182 Kg.)	Best	1
39.22	1.25 (31.8 mm)	Yes	250 (114 Kg.)	Best	1
39.23	1.25 (31.8 mm)	Yes	250 (114 Kg.)	Best	1
39.24	1.25 (31.8 mm)	Yes	400 (182 Kg.)	Best	1
38.10.00.052	1.50 (38.1 mm)	Yes	450 (205 Kg.)	Better	3
38.10.00.051	1.50 (38.1 mm)	Yes	450 (205 Kg.)	Better	3
38.10.00.002	1.50 (38.1 mm)	Yes	450 (205 Kg.)	Better	3
38.10.00.001	1.50 (38.1 mm)	Yes	450 (205 Kg.)	Better	3
SD659	1.25 (31.8 mm)	Yes	150 (68 Kg.)	Better	4
ND659	1.25 (31.8 mm)	No	150 (68 Kg.)	Better	4
1973-9100-25	1.25 (31.8 mm)	Yes	500 (227 Kg.)	Good	2
1973-8000-25	1.50 (38.1 mm)	No	500 (227 Kg.)	Good	2
1973-4000-25	1.25 (31.8 mm)	No	500 (227 Kg.)	Good	2

* Two roller assemblies per door

** Our AAMA certifications are being updated constantly. Please consult AAMA's Verified Components List for an up to date listing of certified patio door roller products.

FIG. 1 APPLICATION OF 39 SERIES PATIO DOOR ROLLER

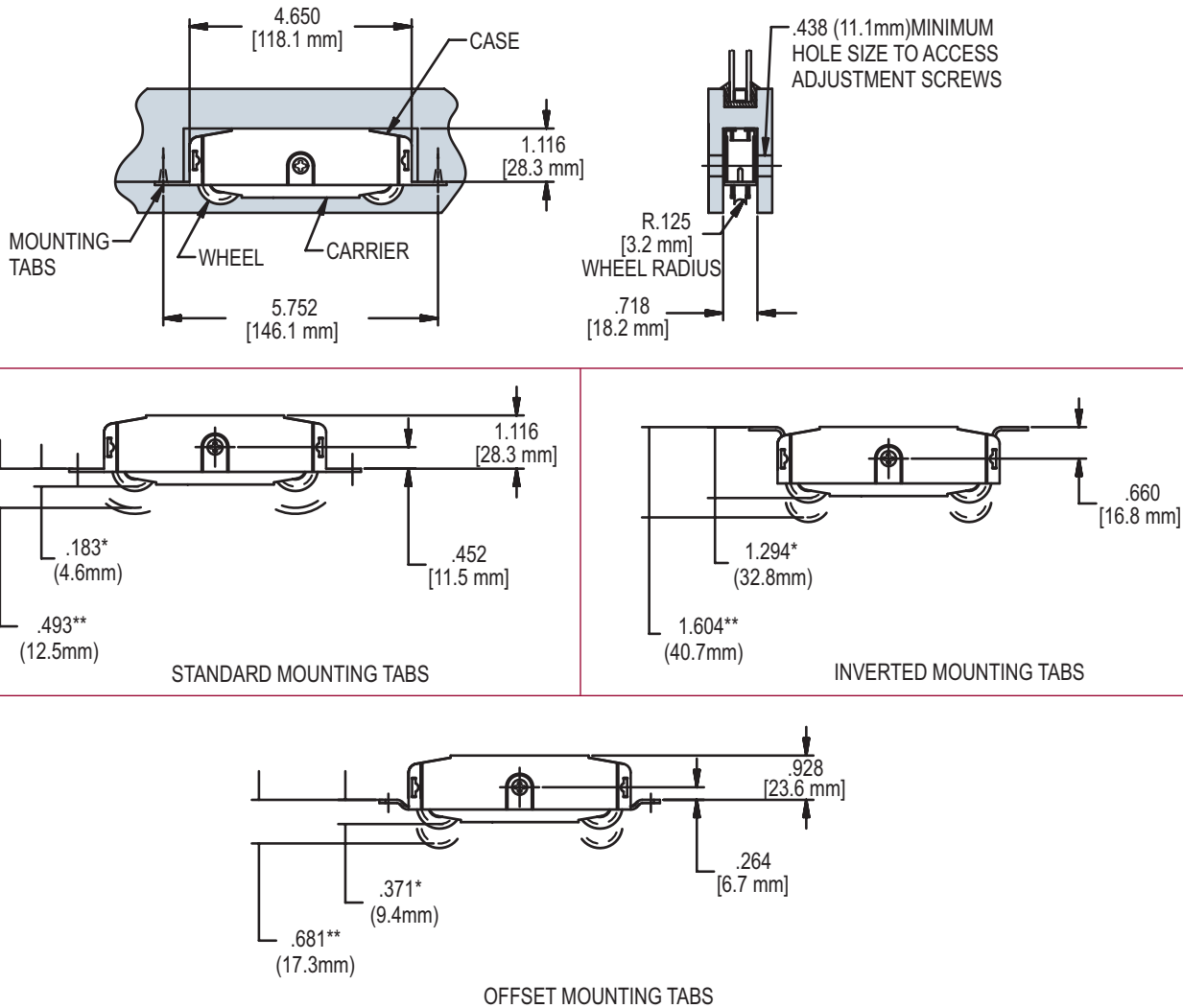

*FULLY RETRACTED WHEEL POSITION-DIMENSION IS TO INSIDE WHEEL RADIUS
 **FULLY EXTENDED WHEEL POSITION-DIMENSION IS TO INSIDE WHEEL RADIUS

PART NO.	CASE AND CARRIER MATERIAL	WHEEL MATERIAL	MOUNTING TABS	SPECIAL FEATURES
39.10	STEEL	STEEL	STANDARD	
39.11	STEEL	NYLON	STANDARD	
39.13	STAINLESS STEEL	STAINLESS STEEL	STANDARD	SST MOUNTING TABS
39.14	STEEL	STEEL	INVERTED	
39.20	STEEL	STAINLESS STEEL	STANDARD	
39.22	STEEL	NYLON	INVERTED	
39.23	STEEL	NYLON	OFFSET	
39.24	STEEL	STEEL	OFFSET	

NOTE:

TRUTH PATIO DOOR ROLLERS ARE ADJUSTABLE FROM BOTH SIDES. WHEN TURNED COUNTER-CLOCKWISE, THE SIDE WITH CROSSED SLOTS RAISES THE DOOR. WHEN TURNED CLOCKWISE, THE SIDE WITH THE SINGLE SLOT RAISES THE DOOR.

RECOMMENDED SCREWS:

(QTY 2)#8 PHILLIPS, FLAT HEAD SCREWS (LENGTH AND THREAD TYPE TO BE DETERMINED BY PROFILE)

SIDE ADJUST TANDEM ROLLERS

FIG. 2 1973 SERIES SIDE ADJUST TANDEM ROLLER

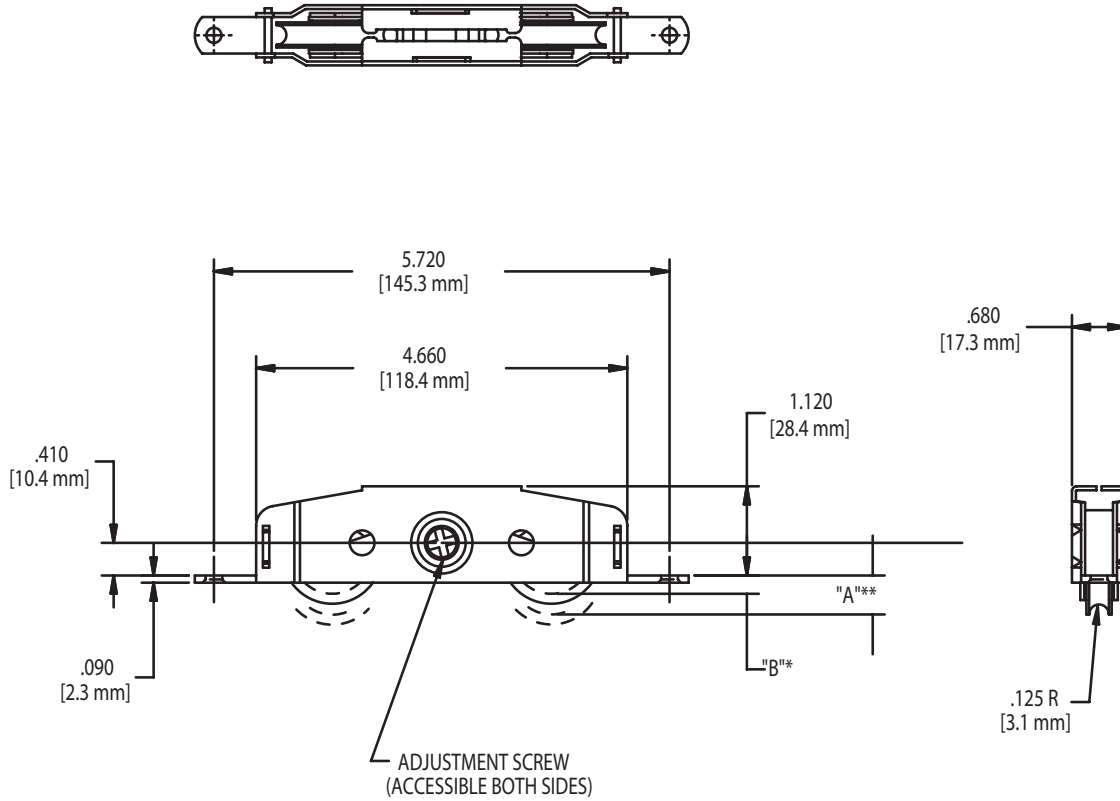

*FULLY RETRACTED WHEEL POSITION-DIMENSION IS TO INSIDE WHEEL RADIUS

**FULLY EXTENDED WHEEL POSITION-DIMENSION IS TO INSIDE WHEEL RADIUS

PART NO.	MATERIAL	WHEEL DIAMETER	"A"*** FULLY EXTENDED	"B"*** FULLY RETRACTED
1973-9100-25	STAINLESS STEEL	1.250	.489	.230
1973-4000-25	STEEL	1.250	.489	.230
1973-8000-25	STAINLESS STEEL	1.500	.614	.355

NOTE:

THE 1973 SERIES PATIO DOOR ROLLERS ARE ADJUSTABLE FROM BOTH SIDES. THE SIDE WITH CROSSED SLOTS RAISES THE DOOR WHEN TURNED CLOCKWISE. THE SIDE WITH THE SINGLE SLOT RAISES THE DOOR WHEN TURNED COUNTER-CLOCKWISE

RECOMMENDED MOUNTING SCREWS:

(QTY 2) #10 PHILLIPS FLAT HEAD SHEET METAL SCREW,
(LENGTH TO BE DETERMINED BY APPLICATION)

FIG. 3 38.10 SERIES TANDEM ROLLER

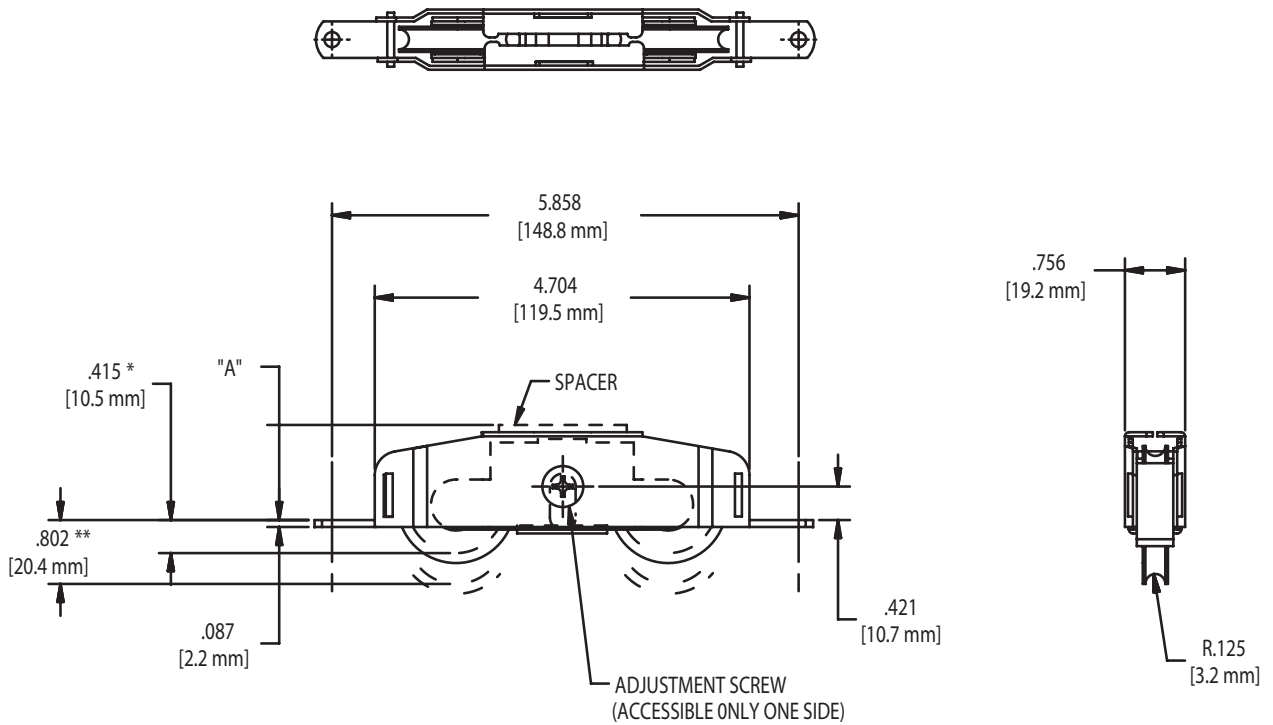

*FULLY RETRACTED WHEEL POSITION-DIMENSION IS TO INSIDE WHEEL RADIUS

**FULLY EXTENDED WHEEL POSITION-DIMENSION IS TO INSIDE WHEEL RADIUS

PART NO.	MATERIAL	"A" HEIGHT	SPACER
38.10.00.001	STEEL	1.103	NO
38.10.00.002	STEEL	1.198	YES
38.10.00.051	STAINLESS STEEL	1.103	NO
38.10.00.052	STAINLESS STEEL	1.198	YES

NOTE:

THE 38.10 SERIES PATIO DOOR ROLLERS ARE ADJUSTABLE FROM ONE SIDE ONLY.
TO RAISE THE DOOR, TURN THE ADJUSTMENT SCREW CLOCKWISE.

RECOMMENDED MOUNTING SCREWS:

(QTY 2) #10 PHILLIPS FLAT HEAD SHEET METAL SCREWS,
(LENGTH TO BE DETERMINED BY APPLICATION)

SIDE ADJUST TANDEM ROLLERS

FIG. 4 659 SERIES ROLLER

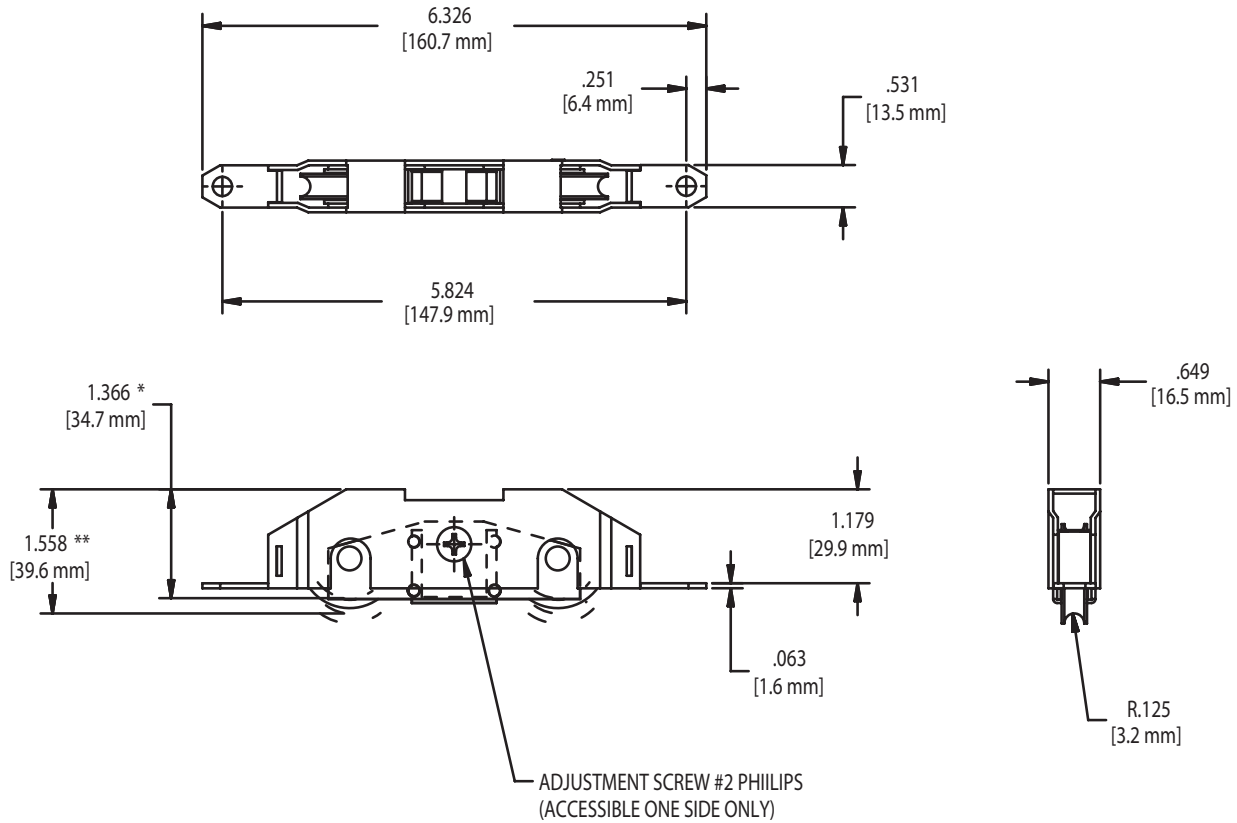

*FULLY RETRACTED WHEEL POSITION-DIMENSION IS TO INSIDE WHEEL RADIUS
 **FULLY EXTENDED WHEEL POSITION-DIMENSION IS TO INSIDE WHEEL RADIUS

PART NO.	MATERIAL
SD659	STEEL
ND659	NYLON

RECOMMENDED MOUNTING SCREWS:

(QTY 2) #10 PHILLIPS FLAT HEAD SCREWS, (LENGTH AND
 THREAD TYPE TO BE DETERMINED BY APPLICATION)