



Expanding our product offering in the line of Multi-Point Locking Systems, Truth introduces - the **Mirage® Concealed Multi-Point Locking System**.

VERSATILE & EFFICIENT

The attractiveness of this system lies in great part to the things that you can't see, because the Mirage's slim-line handle and escutcheon are barely noticeable! The unique design of this locking system also allows the handle and escutcheon to be removable for color changes in the field, or for painting or staining wood trim. Non-handed parts will help in ordering, inventory reduction, and applying this hardware.

CONCEALED MULTI-POINT LOCKING

Truth's patented multi-point locking feature is unique in that it sequentially locks the window from bottom to top. Up to three locking points are achievable using this system allowing the homeowner to securely lock tall, or poorly installed windows, all from just one, convenient location. All locking points are concealed to create a clean look for your window system. The tie bar guides are "pre-located" on the tie bars for quick and easy installation onto the window frame. This system is mounted directly onto the frame thus eliminating any modifications to the frame. Only the stop requires any routing to accept the hardware.

PERFORMANCE & FUNCTION

The secret behind the smooth, low torque, operation of this system is the unique interaction between the tie bars and keeper rollers. Truth's new Mirage Lock has an exceptional .625" (15.9 mm) pull-in. The design of this system has been tested to an average of 245 lbs. per locking point in forced entry testing. It has + .125" vertical and + .075" horizontal lock-up and application forgiveness.

PRODUCT APPLICATION ASSISTANCE

If you are designing a new window profile, or are having difficulty selecting hardware for your window, please contact Truth. Our highly trained Product Specialists can assist you with the selection of the appropriate hardware to meet your performance requirements, as well as providing personalized application drawings.

CORROSION RESISTANCE

Truth's E-Gard® Hardware has a multi-stage coating process that produces a superior physical and aesthetic finish. Plus, it is resistant to a wider range of corrosive materials, including industrial cleaning materials and environmental pollutants. This proprietary process has been tested to be approximately three times better than common zinc plated finishes.

WARRANTY:

Protected under the terms of the Truth Warranty for Window and Door Manufacturers and Authorized Distributors. Refer to Truth's Terms and Conditions for further details.

MATERIAL: High pressure zinc die-cast handle and escutcheon. Steel tie bar with engineered plastic guides. Keepers made of high strength steel and UV resistant acetal rollers.

FINISH: Electrostatically applied, durable coatings that provide excellent resistance to chipping, scratching and corrosion while maintaining color stability for years in direct sunlight. Please refer to Truth's Color Chart for examples of Truth's most popular finish options. Truth also offers a wide range of decorative "plated" finishes - contact Truth for additional information on availability of these finishes on specific product lines.



ORDERING INFORMATION

Contact Truth Hardware for an application drawing providing complete details.

For both Casement & Awning windows:

1. Order non-handed part:
#16.60.XX.001 Mirage® Lock with insert (for solid wood stops), or #16.61.XX.002 Mirage® Lock with insert (for extended stops or vinyl windows.).
2. Specify finish number
3. Order Keeper(s):
#11498.92 Non-handed Keeper
4. Determine tie bars required. Refer to accompanying drawings for part #'s and standard available lengths (handing determined by hinge side when viewed from the outside).

RECOMMENDED SCREWS

Types of screw required determined by material of profile used - see Tech Note #11. Refer to drawings for complete information on screw type and quantity needed on your specific window profiles (sold separately).

TRUTH TIPS

1. Make sure that screen stop fasteners do not interfere with the movement of the tie bar.
2. Application drawings show correct orientation of keepers to insure sequential lock-up.
3. When selecting mounting screws for Truth hardware, coating screws compatibility is a very important criteria. For best corrosion resistance, the coating on the screws should be the same as the coating on the hardware.
4. For accurate hardware placement pre-drilling the window profile is recommended. The most critical is the Insert Link screw.
5. Truth recommends that a Snubber be used at the center of the hinge side on any casement window which has a tendency to bow outwardly at the center in the closed position. Adding a Snubber may increase the negative air pressure rating of the window.

**INCLUDE TRUTH SPECS ON
YOUR NEXT WINDOW PROJECT**

Window locking system shall be included which will increase both security and weather seal tightness. The locking points must hold securely for negative air pressure and forced entry resistance.

Window sash locks will be used which provides .625" (15.9 mm) of pull-in. The lock must utilize a tie bar driven by a single locking handle to meet ADA hardware height standards. The lock must incorporate a multi-point locking feature that sequentially locks the window from bottom to top. The lock must provide for a removable handle and escutcheon for ease in color changes and/or for ease in painting or staining the window. The lock shall be constructed of high pressure zinc alloy die castings, internal E-Gard® hardware, and high quality engineered plastics.

Window locks shall be 16 series, **Mirage®** as manufactured by Truth Hardware, Owatonna, MN.

FIG. 1 APPLICATION WITH TWO OR THREE LOCKING POINTS

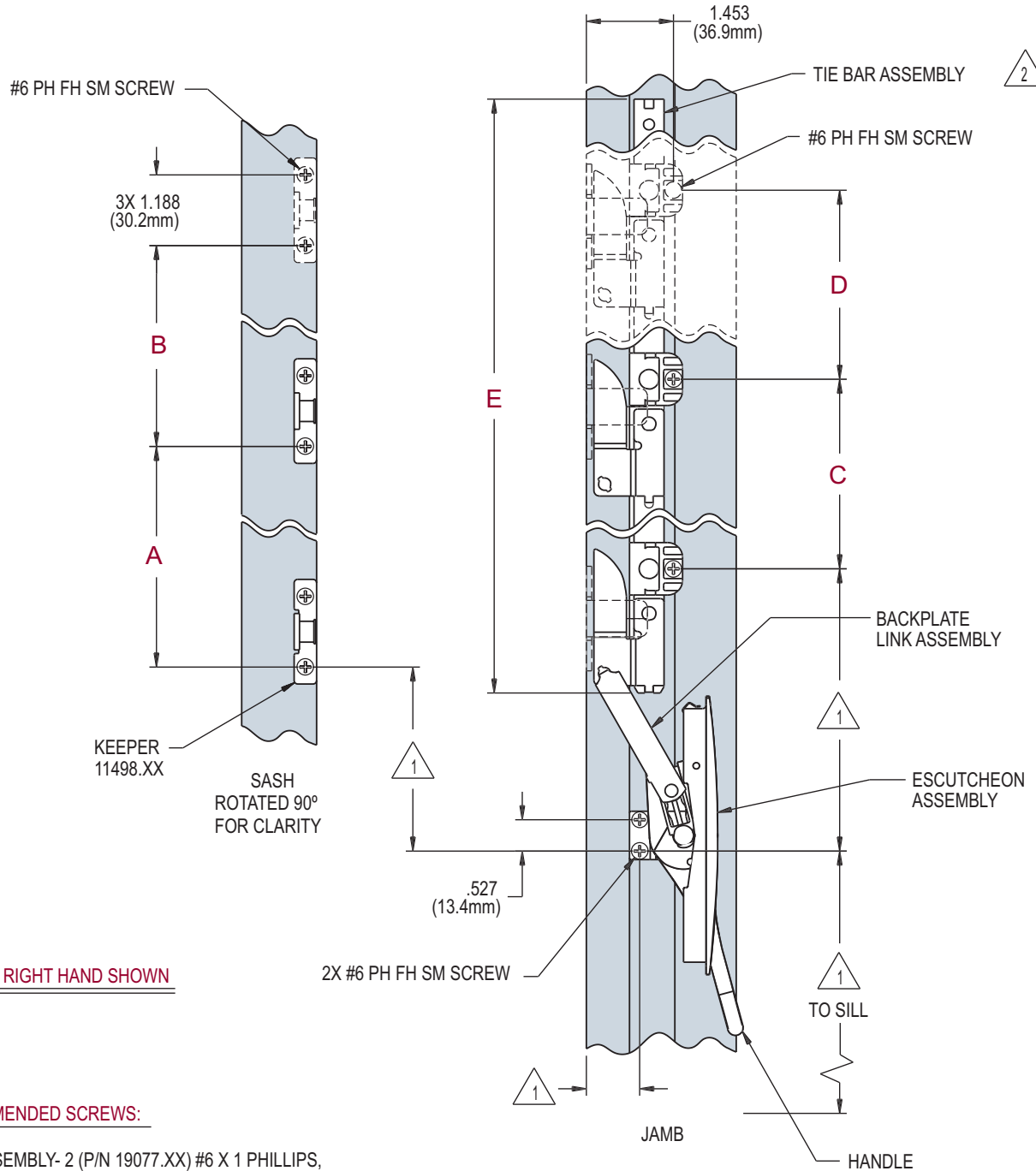

RIGHT HAND SHOWN

RECOMMENDED SCREWS:

- LINK ASSEMBLY- 2 (P/N 19077.XX) #6 X 1 PHILLIPS, PAN HEAD, SHEET METAL SCREW
- TIE BAR ASSEMBLY - (P/N 19077.XX) #6 X 1 PHILLIPS, PAN HEAD, SHEET METAL SCREW (1 PER LOCKING POINT)
- KEEPER - (P/N 19051.XX) #6 X 1 PHILLIPS, FLAT HEAD, SHEET METAL SCREW (2 PER LOCKING POINT)

PART NUMBER	DESCRIPTION
16.60.XX	ESCUTCHEON, HANDLE AND LINK ASSEMBLY
△ 2	TIE BAR ASSEMBLY (HANDED)
11498.XX	KEEPER (NON-HANDED)

XX DENOTES FINISH CODE

NOTES:

- △ 1 VARIABLE DIMENSION - DEPENDENT ON CUSTOMER PROFILE. CONTACT TRUTH FOR YOUR SPECIFIC APPLICATION.
- △ 2 SEE FIGURE 3 FOR PART NUMBERS AND DIMENSIONS **A, B, C, D** AND **E**
- 3. SEE FIGURE 2 FOR STOP ROUTING DETAIL
- 4. SEE FIGURE 10 FOR PROFILE VIEW.
- 5. SEQUENTIAL LOCK-UP BETWEEN FIRST AND SECOND KEEPERS ONLY.



16 MIRAGE® CONCEALED MULTI-POINT LOCKING SYSTEM (Tie Bar in Jamb version)

FIG. 2 SIDE STOP ROUTING DETAIL (2 AND 3 LOCKING POINT)

2 POINT LOCKING SYSTEM

TIE BAR E DIM	X 
16.175 in (410.8 mm)	20.536 (521.6mm)
22.175 in (563.2 mm)	26.536 (674.0mm)
28.175 in (715.6 mm)	32.536 (826.4mm)
34.175 in (868 mm)	38.536 (978.8mm)
40.175 in (1020.4 mm)	44.536 (1131.2mm)
46.175 in (1172.8 mm)	50.536 (1283.6mm)
52.175 in (1325.2 mm)	56.536 (1436.0mm)

3 POINT LOCKING SYSTEM

TIE BAR E DIM	X 	Y 
34.175 in (868.0mm)	23.596 (599.3mm)	38.596 (980.3mm)
40.175 in (1020.4 mm)	26.596 (675.5mm)	44.596 (1132.7mm)
46.175 in (1172.8 mm)	29.596 (751.7mm)	50.596 (1285.1mm)
52.175 in (1325.2 mm)	32.596 (827.9mm)	56.596 (1437.5mm)

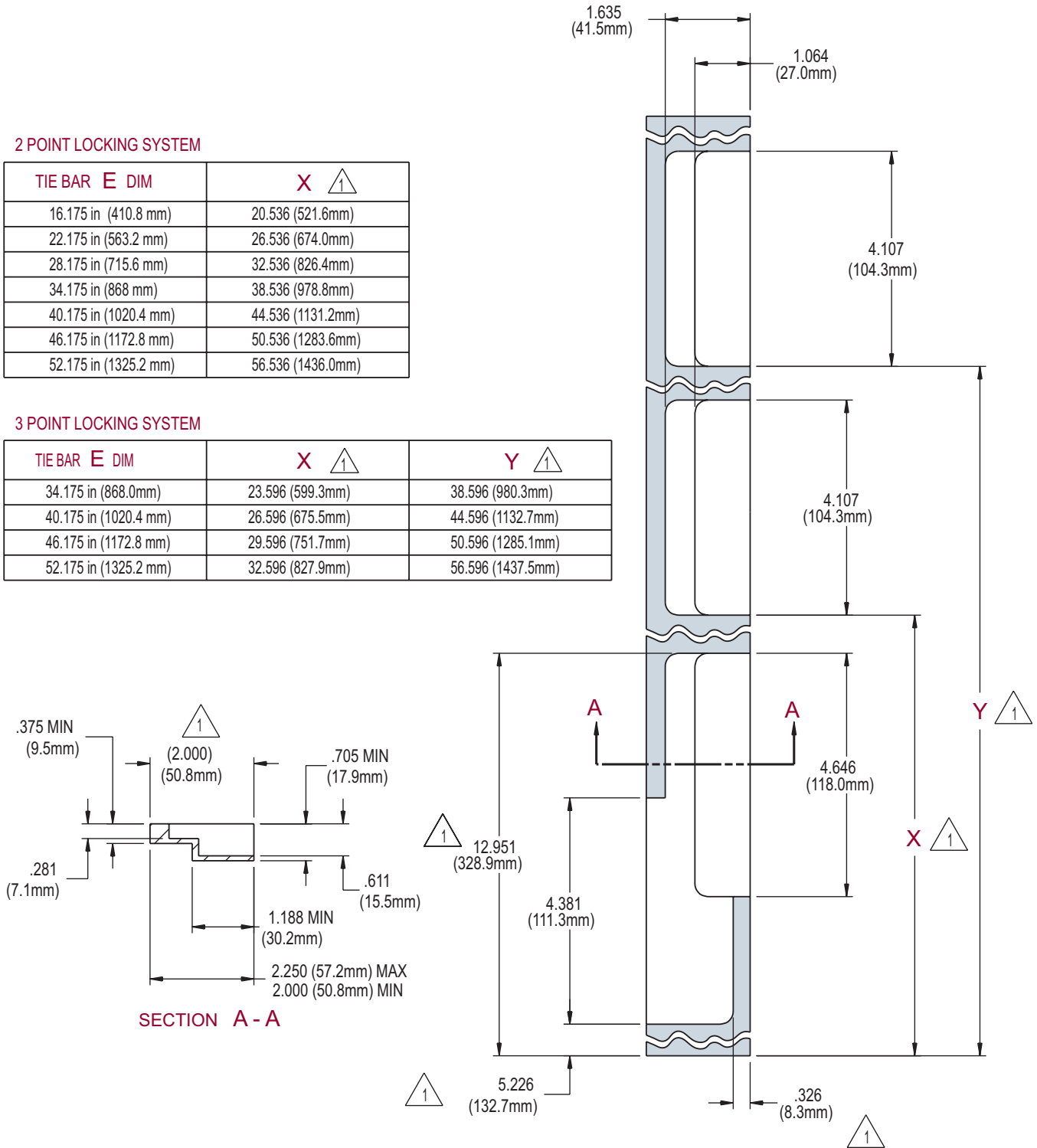

RIGHT HAND SHOWN

NOTES:

 VARIABLE DIMENSION - DEPENDENT ON CUSTOMER HANDLE LOCATION PREFERENCE AND PROFILES. DIMENSIONS SHOWN ARE FOR REFERENCE ONLY. EXAMPLE SHOWN OF A 2.000" STOP. CONTACT TRUTH FOR YOUR SPECIFIC APPLICATION.

FIG. 3 TIE BAR ASSEMBLY CHART



2 POINT TIE BAR ASSEMBLIES				KEEPER TO KEEPER		
PART NUMBER		DIMENSIONS			DIMENSIONS	
LH	RH	D DIM	E DIM	A DIM		
11507.XX	11508.XX	11.75 in (298.5mm)	16.175 in (410.8mm)	12.00 in (304.8mm)		
11509.XX	11510.XX	17.75 in (450.9mm)	22.175 in (563.2mm)	18.00 in (457.2mm)		
11511.XX	11512.XX	23.75 in (603.3mm)	28.175 in (715.6mm)	24.00 in (609.6mm)		
11513.XX	11514.XX	29.75 in (755.7mm)	34.175 in (868mm)	30.00 in (762mm)		
11515.XX	11516.XX	35.75 in (908.1mm)	40.175 in (1020.4mm)	36.00 in (914.4mm)		
11517.XX	11518.XX	41.75 in (1060.5mm)	46.175 in (1172.8mm)	42.00 in (1066.8mm)		
11519.XX	11520.XX	47.75 in (1212.9mm)	52.175 in (1325.2mm)	48.00 in (1219.2mm)		

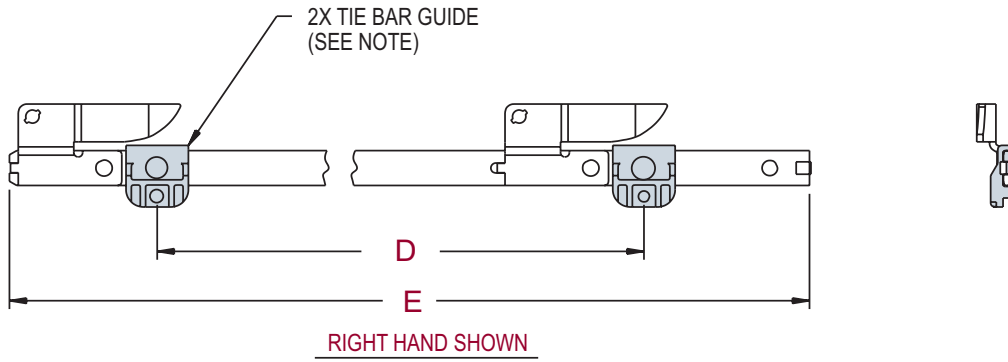
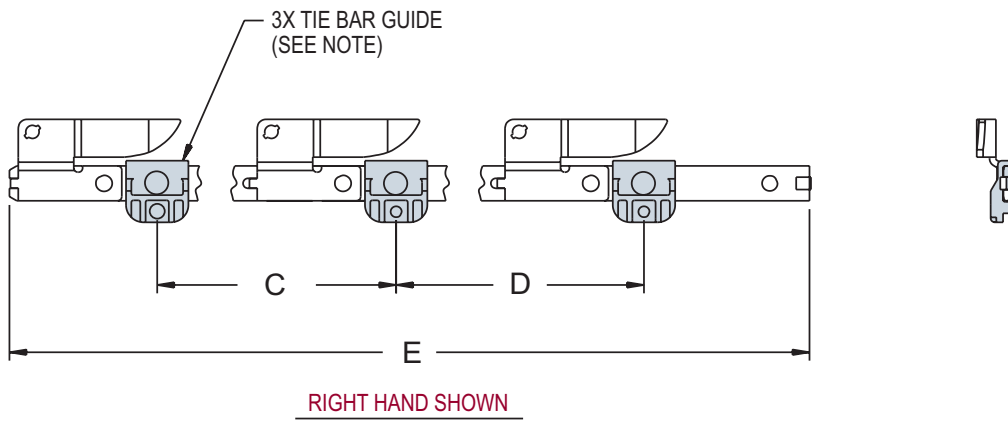

3 POINT TIE BAR ASSEMBLIES					KEEPER TO KEEPER	
PART NUMBER		DIMENSIONS			DIMENSIONS	
LH	RH	C DIM	D DIM	E DIM	A DIM	B DIM
11521.XX	11522.XX	14.75 in (298.5mm)	15.00 in (381 mm)	34.175 in (868 mm)	15.00 in (381 mm)	15.00 in (381 mm)
11523.XX	11524.XX	17.75 in (450.9mm)	18.00 in (457.2mm)	40.175 in (1020.4 mm)	18.00 in (457.2mm)	18.00 in (457.2mm)
11525.XX	11526.XX	20.75 in (527.1mm)	21.00 in (533.4mm)	46.175 in (1172.8 mm)	21.00 in (533.4mm)	21.00 in (533.4mm)
11527.XX	11528.XX	23.75 in (603.3mm)	24.00 in (609.6mm)	52.175 in (1325.2 mm)	24.00 in (609.6mm)	24.00 in (609.6mm)

XX DENOTES FINISH CODE

NOTE:

1. TIE BAR GUIDES ARE PRE-LOCATED ON BAR.

16 MIRAGE® CONCEALED MULTI-POINT LOCKING SYSTEM (Tie Bar in Jamb version)

FIG. 4 APPLICATION OF SINGLE LOCKING POINT

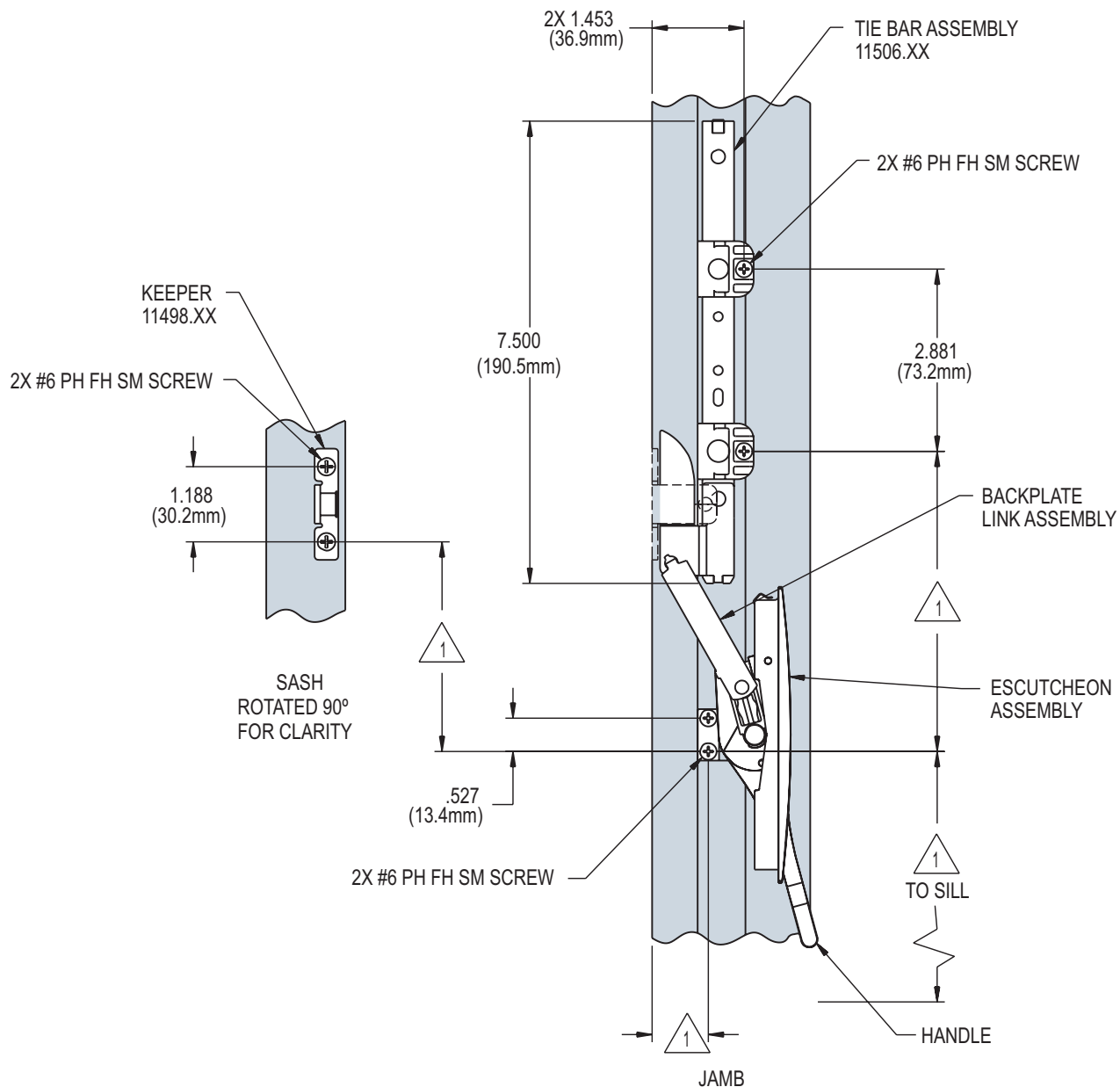

RECOMMENDED SCREWS:

- LINK ASSEMBLY- 2 (P/N 19077.XX) #6 X 1 PHILLIPS, PAN HEAD, SHEET METAL SCREW
- TIE BAR ASSEMBLY - 2 (P/N 19077.XX) #6 X 1 PHILLIPS, PAN HEAD, SHEET METAL SCREW
- KEEPER- 2 (P/N 19051.XX) #6 X 1 PHILLIPS, FLAT HEAD, SHEET METAL SCREW

RIGHT HAND SHOWN

PART NUMBER	DESCRIPTION
16.60.XX	ESCUTCHEON, HANDLE AND LINK ASSEMBLY
11506.XX	RH TIE BAR ASSEMBLY (LH P/N 11505.XX)
11498.XX	KEEPER (NON-HANDED)

NOTE:

- 1 VARIABLE DIMENSION - DEPENDENT ON CUSTOMER PROFILE. CONTACT TRUTH FOR YOUR SPECIFIC APPLICATION.
- 2. SEE FIGURE 5 FOR STOP ROUTING DETAIL.
- 3. SEE FIGURE 10 FOR PROFILE VIEW.

XX DENOTES FINISH CODE

FIG. 5 SIDE STOP ROUTING DETAIL (SINGLE LOCKING POINT)

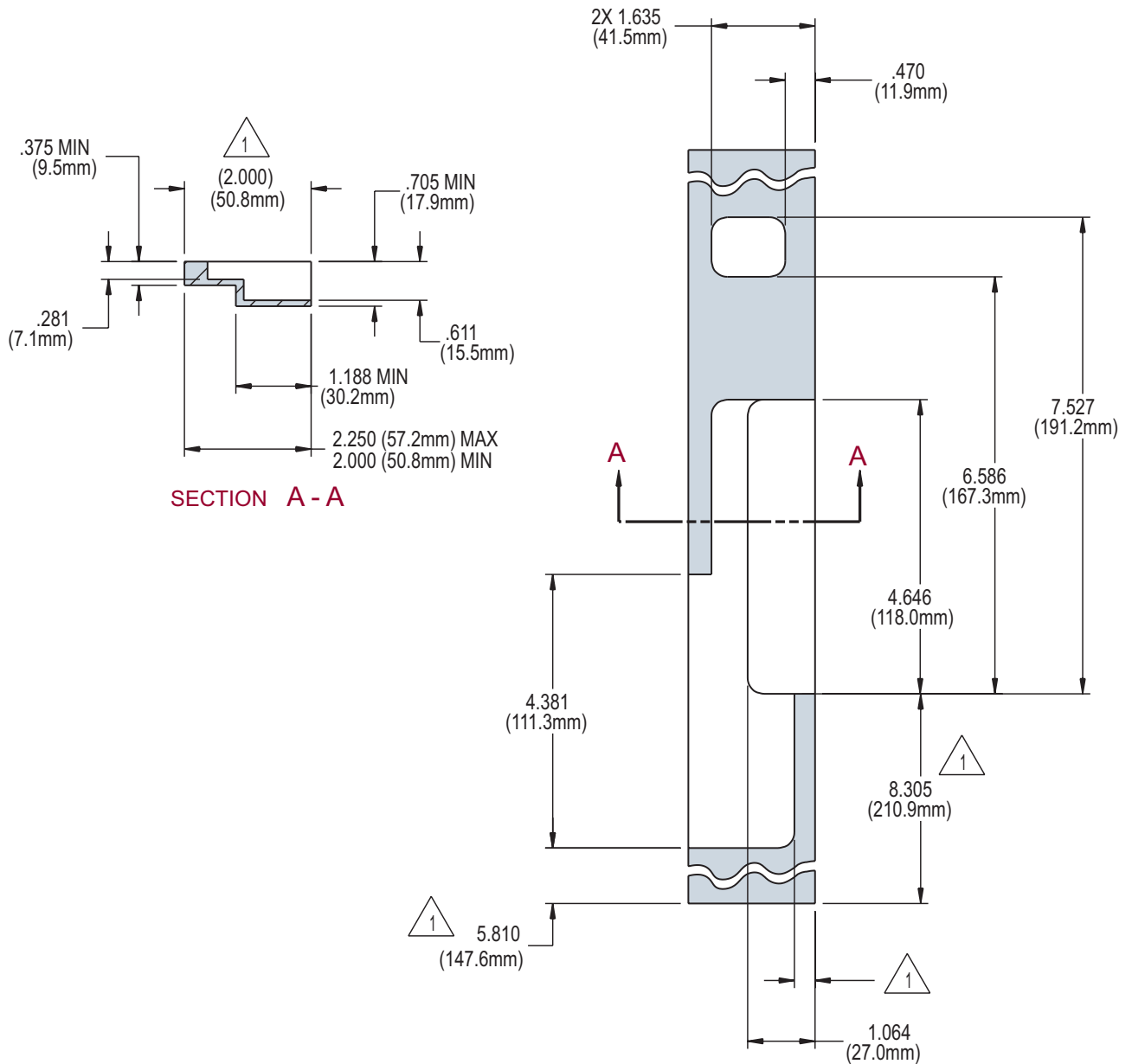

SECTION A-A

RIGHT HAND SHOWN

NOTES:

-  VARIABLE DIMENSION - DEPENDENT ON CUSTOMER HANDLE LOCATION PREFERENCE AND PROFILES. DIMENSIONS SHOWN ARE FOR REFERENCE ONLY. EXAMPLE SHOWN IS A 2.000" STOP. CONTACT TRUTH FOR YOUR SPECIFIC APPLICATION.

16 MIRAGE® CONCEALED MULTI-POINT LOCKING SYSTEM (Tie Bar in Jamb version)

FIG. 6 APPLICATION OF SINGLE POINT WITH DRIVER MECHANISM

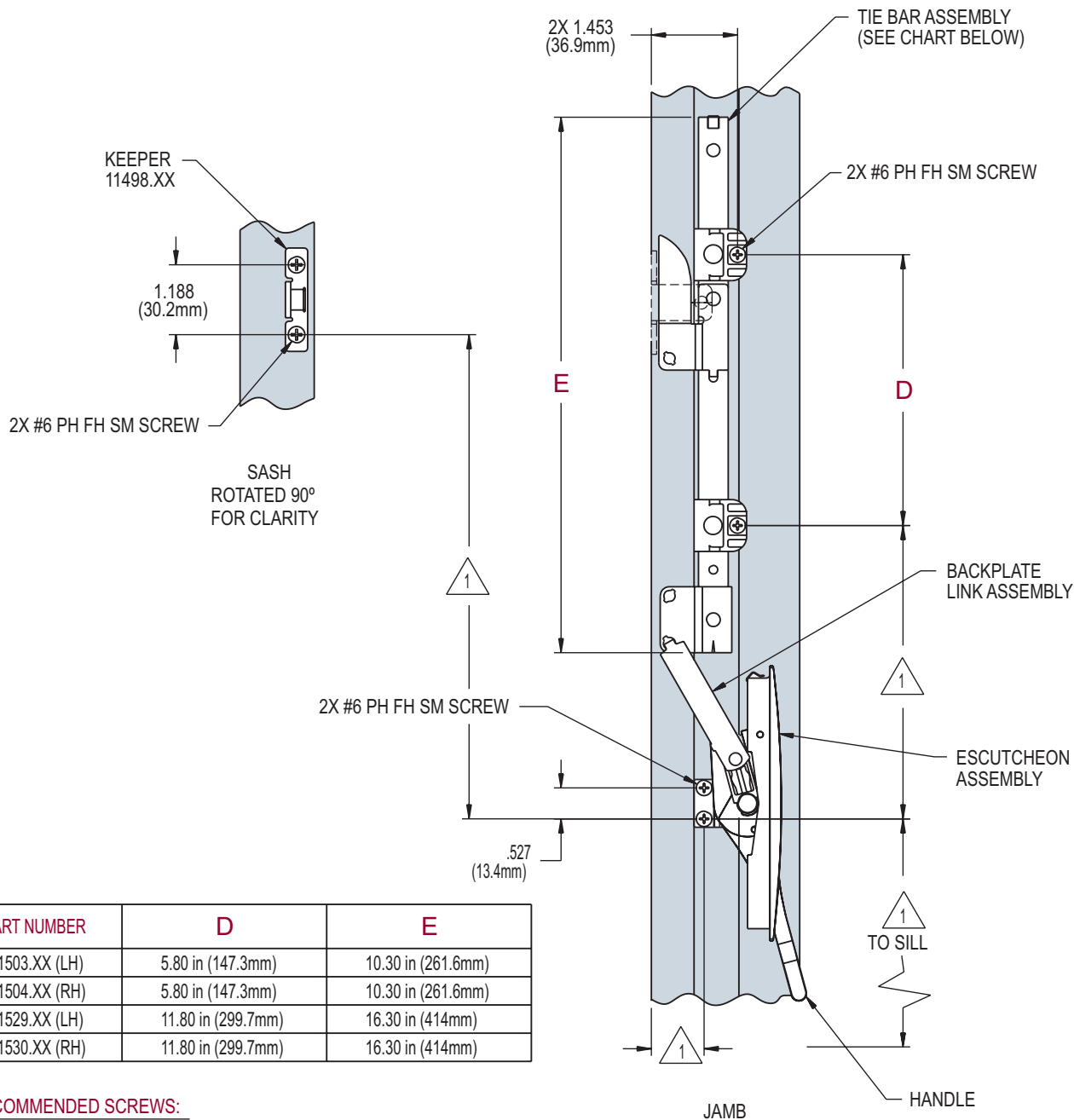

PART NUMBER	D	E
11503.XX (LH)	5.80 in (147.3mm)	10.30 in (261.6mm)
11504.XX (RH)	5.80 in (147.3mm)	10.30 in (261.6mm)
11529.XX (LH)	11.80 in (299.7mm)	16.30 in (414mm)
11530.XX (RH)	11.80 in (299.7mm)	16.30 in (414mm)

RECOMMENDED SCREWS:

- LINK ASSEMBLY- 2 (P/N 19077.XX) #6 X 1 PHILLIPS, PAN HEAD, SHEET METAL SCREW
- TIE BAR ASSEMBLY - 2 (P/N 19077.XX) #6 X 1 PHILLIPS, PAN HEAD, SHEET METAL SCREW
- KEEPER- 2 (P/N 19051.XX) #6 X 1 PHILLIPS, FLAT HEAD, SHEET METAL SCREW

PART NUMBER	DESCRIPTION
16.60.XX	ESCUTCHEON, HANDLE AND LINK ASSEMBLY
*	TIE BAR ASSEMBLY
11498.XX	KEEPER (NON-HANDED)

* SEE CHART ABOVE
XX DENOTES FINISH CODE

RIGHT HAND SHOWN

- NOTE:
- 1 VARIABLE DIMENSION - DEPENDENT ON CUSTOMER PROFILE - CONTACT TRUTH FOR YOUR SPECIFIC APPLICATION.
 - 2. SEE FIGURE 7 FOR STOP ROUTING DETAIL.
 - 3. SEE FIGURE 10 FOR PROFILE VIEW.

FIG. 7 SIDE STOP ROUTING DETAIL (SINGLE POINT WITH DRIVER MECHANISM)

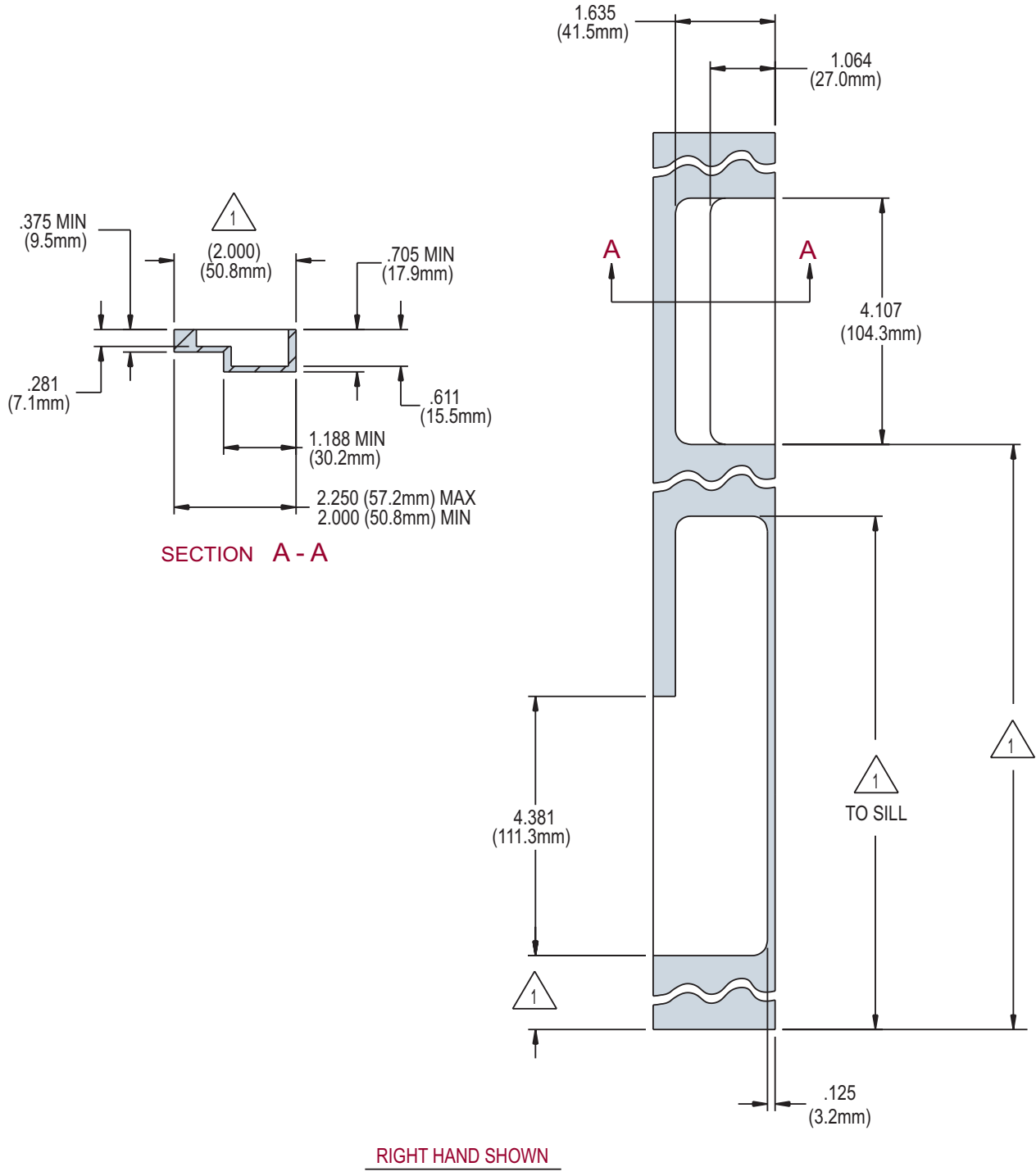

NOTES:

- VARIABLE DIMENSION - DEPENDENT ON CUSTOMER HANDLE LOCATION PREFERENCE AND PROFILES. DIMENSIONS SHOWN ARE FOR REFERENCE ONLY. EXAMPLE SHOWN IS A 2.000" STOP. CONTACT TRUTH FOR YOUR SPECIFIC APPLICATION.

16 MIRAGE® CONCEALED MULTI-POINT LOCKING SYSTEM (Tie Bar in Jamb version)

FIG. 8 AWNING APPLICATION

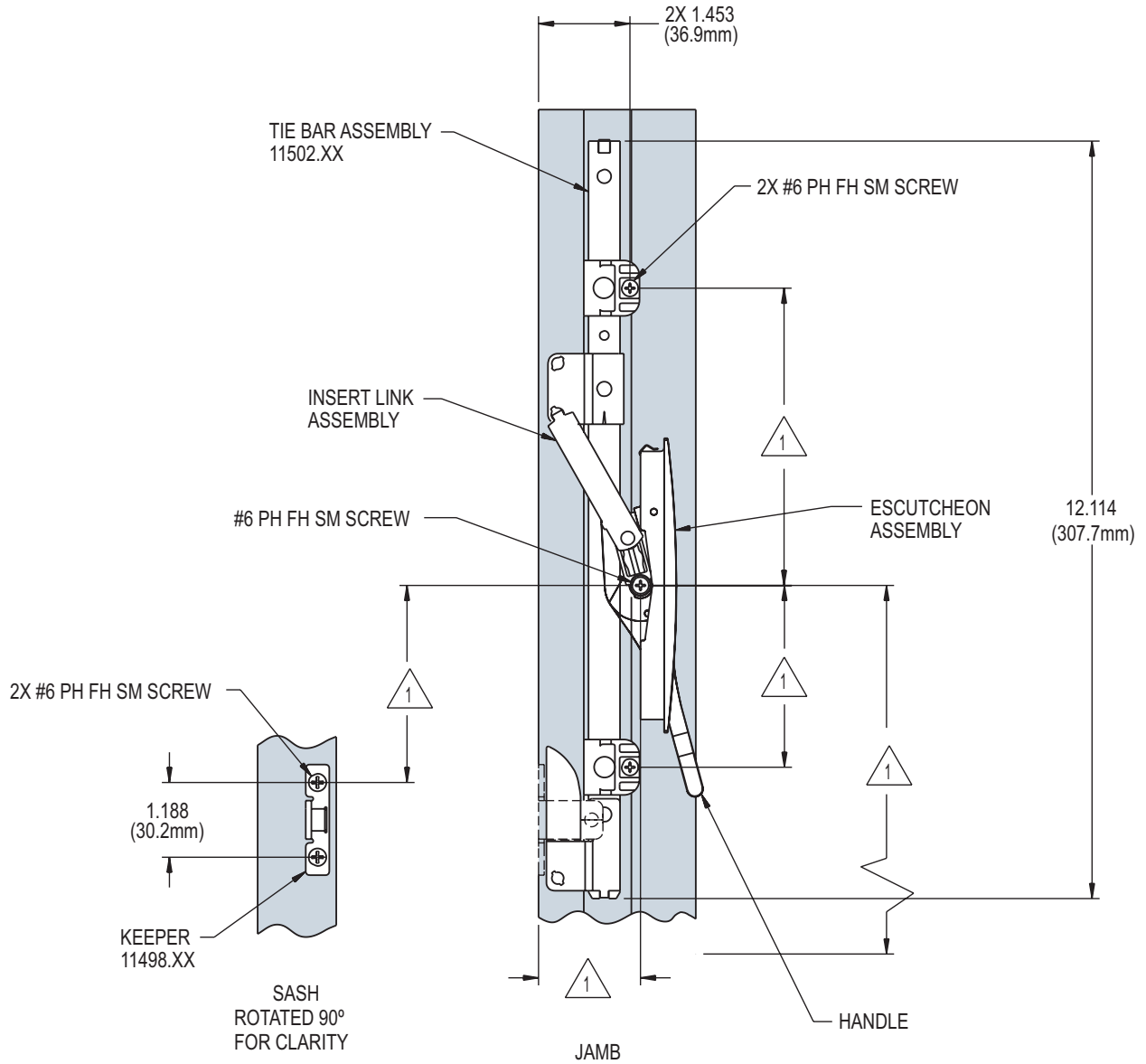

RIGHT HAND SHOWN

RECOMMENDED SCREWS:

- LINK ASSEMBLY- 1 (P/N 19077.XX) #6 X 1 PHILLIPS, PAN HEAD, SHEET METAL SCREW
- TIE BAR ASSEMBLY - 2 (P/N 19077.XX) #6 X 1 PHILLIPS, PAN HEAD, SHEET METAL SCREW
- KEEPER- 2 (P/N 19051.XX) #6 X 1 PHILLIPS, FLAT HEAD, SHEET METAL SCREW

PART NUMBER	DESCRIPTION
16.61.XX	ESCUTCHEON, HANDLE AND LINK ASSEMBLY
11502.XX	RH TIE BAR ASSEMBLY (LH P/N 11501.XX)
11498.XX	KEEPER (NON-HANDED)

NOTE:

- 1 VARIABLE DIMENSION - DEPENDENT ON CUSTOMER PROFILE. CONTACT TRUTH FOR YOUR SPECIFIC APPLICATION.
- 2. SEE FIGURE 9 FOR STOP ROUTING DETAIL.
- 3. SEE FIGURE 10 FOR PROFILE VIEW.

XX DENOTES FINISH CODE

FIG. 9 SIDE STOP ROUTING DETAIL (AWNING)

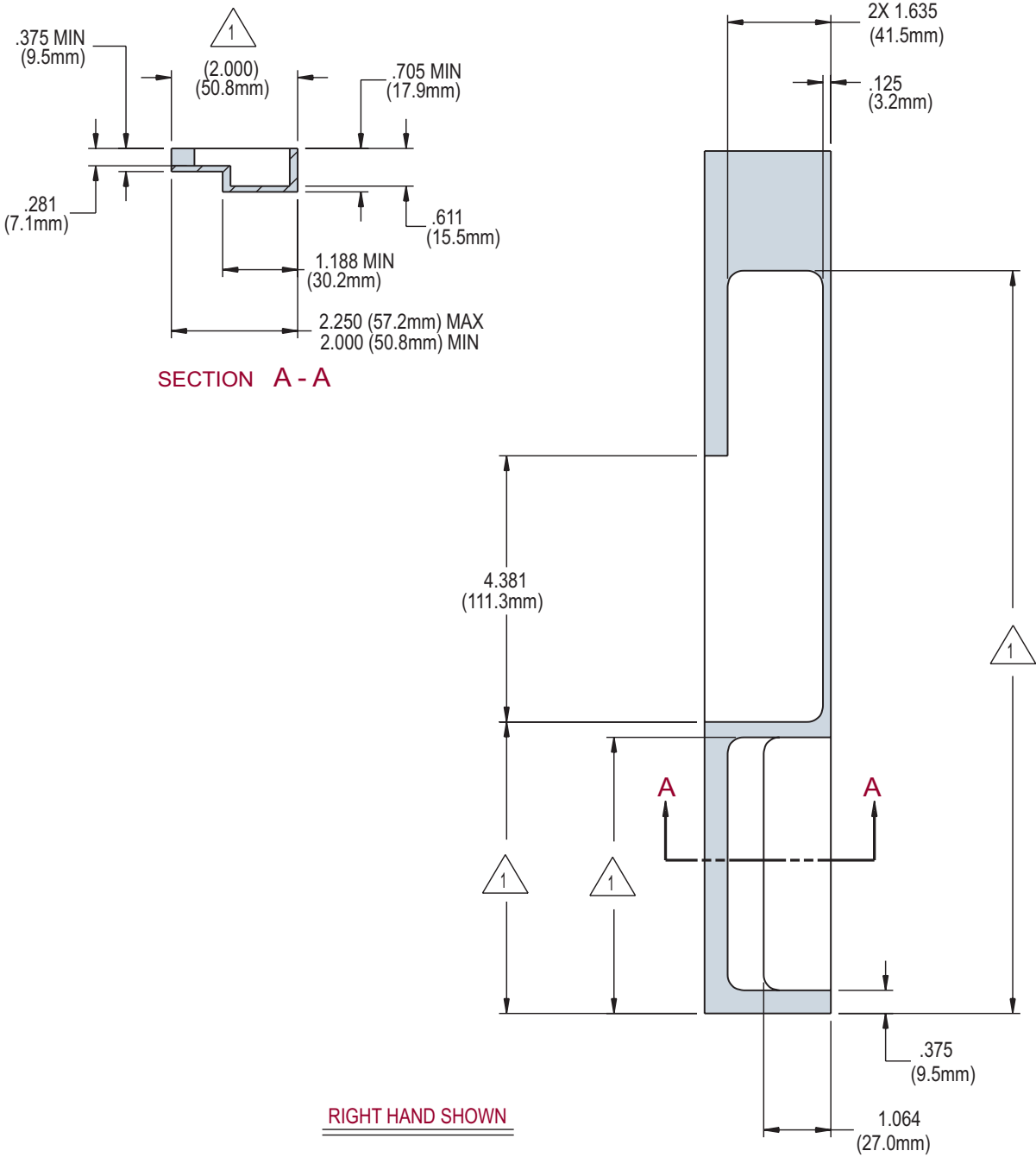

RIGHT HAND SHOWN

NOTES:

 VARIABLE DIMENSION - DEPENDENT ON CUSTOMER HANDLE LOCATION PREFERENCE AND PROFILES. DIMENSIONS SHOWN ARE FOR REFERENCE ONLY. EXAMPLE SHOWN IS A 2.000" STOP. CONTACT TRUTH FOR YOUR SPECIFIC APPLICATION.

FIG. 10 END VIEW DETAIL

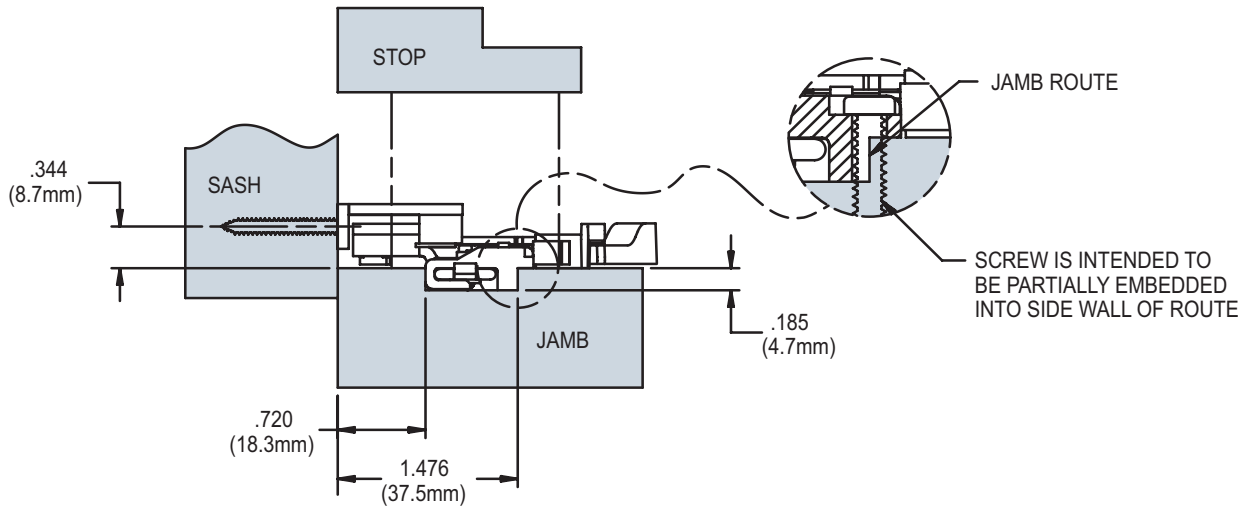
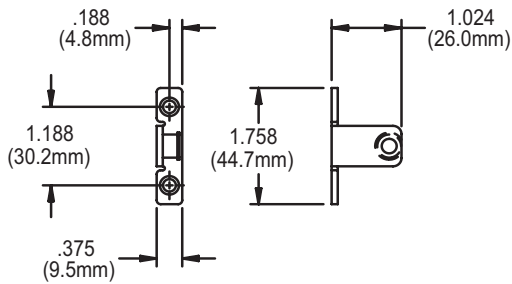

FIG. 11 KEEPER 11498.XX



RECOMMENDED SCREWS:

2 (P/N 19051.XX) #6 X 1 PHILLIPS, FLAT HEAD, SHEET METAL SCREW

FIG. 12 HANDLE (45265), ESCUTCHEON (45376)

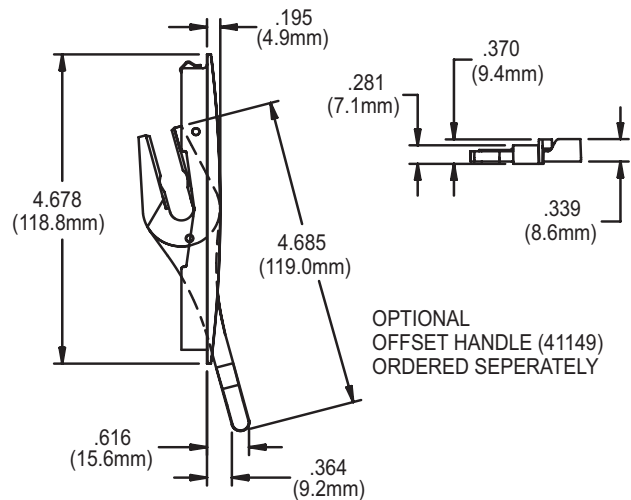
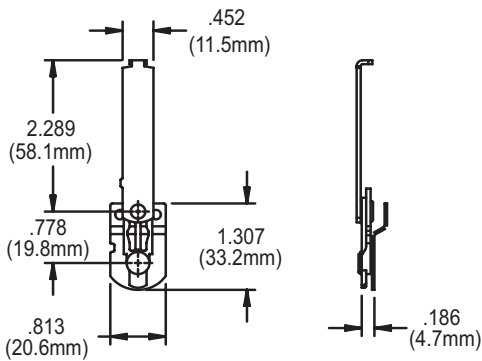

FIG. 13 BACKPLATE LINK ASSEMBLY (11645.92)



RECOMMENDED SCREWS:

2 (P/N 19077.XX) #6 X 1 PHILLIPS, PAN HEAD, SHEET METAL SCREW

FIG. 14 INSERT LINK ASSEMBLY (11648.92)

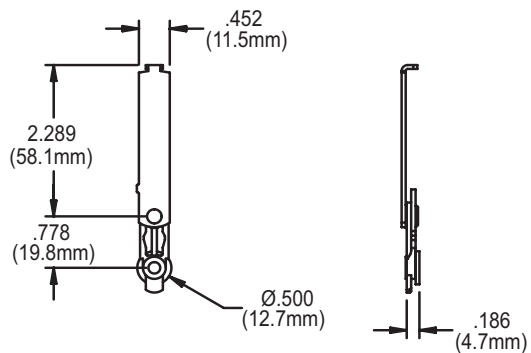

RECOMMENDED SCREW:

1 (P/N 19077.XX) #6 X 1 PHILLIPS, PAN HEAD, SHEET METAL SCREW